



Specification Information

Product Code: 975

Product Name: Retractable and Reversible Shower Seat, Handicap

Individual Carton UPC: 624622975203

Individual Carton Shipping Dimensions: 86.4cm W x 14.0cm H x 71.1cm D (34" W x 5.5" H x 28" D)

Individual Carton Shipping Weight: 12.7kg (28 lbs)

Site Location: Frost's 975 retractable and reversible handicap shower seat is extremely durable and practical. This unit has a barrier free design and comes in right hand configuration, but can be easily switched to left hand. Typically, these units are used in schools/universities, hospitals, and retirement and nursing home communities. The durable construction, large weight capacity, and barrier free design make this unit a popular hygienic solution.

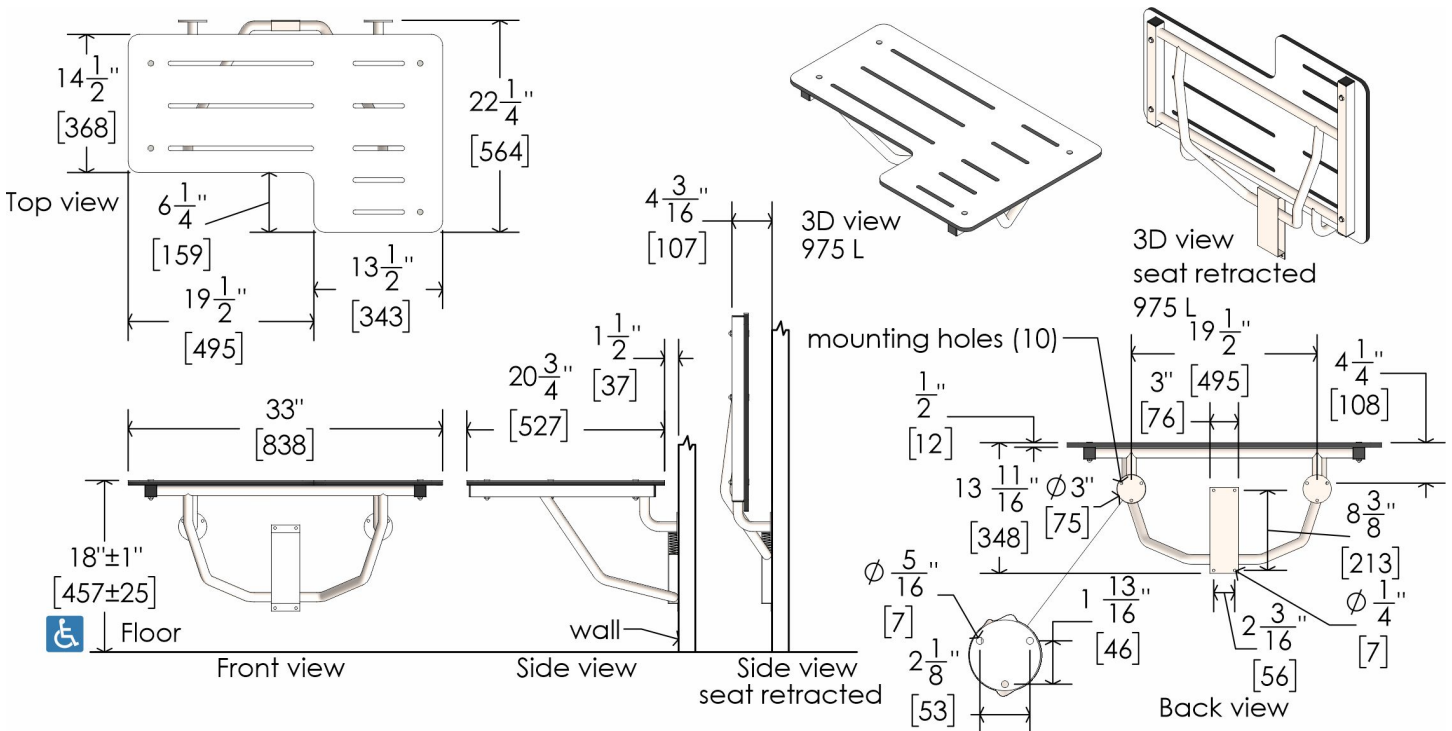

Features:

- Flip up shower seat retracts out of way when not in use
- Reversible between right and left configuration with 10mm ratchet
- White phenolic seat
- Easy to clean and maintain
- Welded construction, features full 360 degree welds on all joints

Capacity

- The folding shower seat is fabricated of adequate strength to support a load of 450 pounds (204.1 kg) and unit shall conform to size and edge clearances as diagrammed. Mounting to the wall is a critical part of the system to meet this requirement. To withstand the shear, tension or pullout, and torsion loads generated by the maximum loading, the fastener system must be adequately sized. Unit is load rated to support a weight of 450 lbs at front edge when properly installed and has been tested to successfully hold a weight in excess of 1000 lbs. Unit shall satisfy ADA Accessibility Guidelines when mounted properly.

Frost Products Ltd

5276 John Lucas Drive
Burlington, ON, Canada, L7L5Z9

(905) 332-5700
1-800 667-5094

info@frostproductsltd.com
www.frostproductsltd.com



Specification Information

Materials:

- Unit frame is fabricated from 1" O.D. 18 gauge brushed finish type 304 stainless steel
- Support and flanges are also stainless steel with brushed finish
- One piece phenolic top, ½" (13mm) thick

Product Dimensions:

- 83.8cm W x 52.7cm H x 56.5cm D (33.0" W x 20.7" H x 22.2" D)

Product Weight:

- 11.6kg (25.5 lbs)

Installation Guidelines: This unit is surface mounted. Installer/construction contractor must provide concealed anchor plate or blocking as specified in construction documents or as required by local building codes prior to wall finishing. Fasten unit flanges and guide bracket to concealed anchor or blocking plate with appropriate hardware. Note that concealed mounting plates or anchors and hardware are not supplied with this product and must be specified separately. Ensure that mounting configuration complies with local building codes. Mounting hole locations are for reference when providing in wall support. Final holes should be drilled using shower seat as a template. **Safety Warning:** All shower seats must be installed by qualified tradesperson. Installers must consult and comply with local building codes. Mounting hardware and other systems to be determined by contractor and installer pending specific structure, design, and conditions. All installations must be fully inspected and approved by property owners and maintenance personnel prior to seat being put into use. Failure to comply with proper installation procedure will void warranty and may result in malfunctioning or injury.

Maintenance: Normal preventative maintenance and cleaning will keep Frost products functioning properly and may extend normal product life. Products should be wiped down with a damp soft cloth periodically. Approved stainless steel cleaner may be used to clean scuffs or fingerprints on stainless surfaces. Do not use harsh detergents or chemical cleaners. For stainless steel please do not spray with any product containing bleach, acids, or chlorides, which can be found in many cleaning products such as toilet bowl cleaners. Use of these cleaning solutions may cause discoloration and if used for prolonged periods of time they can eat away at points in the stainless steel. If discoloration occurs, the use of an approved stainless steel cleaner and a firmer scrub pad, such as a Scotch Brite Pad #7447, may remove the markings. Wipe away any debris from the area and gently rub with the pad. Then spray the area with a stainless steel cleaner/polish and rinse and dry. Always wipe with the grain direction for stainless steel products. If a cleaning agent has begun to eat away at the steel on a unit then the unit will likely need to be replaced. The stainless steel that Frost Products uses is of high quality and stainless steel is resistant to rust. However, discoloration that appears to be rust can be caused by cleaning solutions and soaps mentioned above. It is important to discontinue use of any cleaning agent or soap if discoloration begins to occur. Clean off the discoloration as quickly as possible to avoid any permanent damage to the unit. Maintenance staff should be taught how to recognize the signs that they are not using the appropriate cleaning products and how to correctly maintain stainless steel items.

Warranty: If any product or part proves to be defective within 12 months from date of shipment from the factory it will be repaired or replaced without any charge including freight costs when authorized. Costs resulting from the installation or removal of defective products are not covered under this warranty. Discoloration to stainless steel parts resulting from exposure to harsh environmental and / or chemicals are not considered to be defects in workmanship or material and are not covered under warranty.

Frost Products Ltd

5276 John Lucas Drive
Burlington, ON, Canada, L7L5Z9

(905) 332-5700
1-800 667-5094

info@frostproductsltd.com
www.frostproductsltd.com